

# Panasonic<sup>®</sup>

## Color CCTV Cameras Operating Instructions

Model No. **WV-CW484 Series**

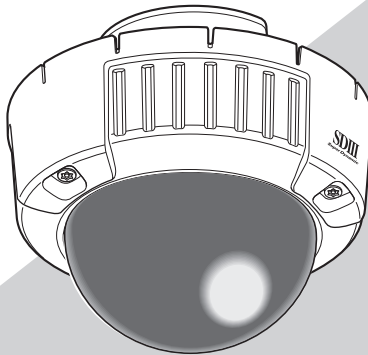



(Lens is option.)

WV-CW484F is shown above.

Before attempting to connect or operate this product,  
please read these instructions carefully and save this manual for future use.

No model number suffix is shown in this manual.

	<b>CAUTION</b> RISK OF ELECTRIC SHOCK DO NOT OPEN	
<p>CAUTION: TO REDUCE THE RISK OF ELECTRIC SHOCK, DO NOT REMOVE COVER (OR BACK). NO USER-SERVICEABLE PARTS INSIDE. REFER SERVICING TO QUALIFIED SERVICE PERSONNEL.</p>		



SA 1965

The lightning flash with arrow-head symbol, within an equilateral triangle, is intended to alert the user to the presence of uninsulated "dangerous voltage" within the product's enclosure that may be of sufficient magnitude to constitute a risk of electric shock to persons.



SA 1966

The exclamation point within an equilateral triangle is intended to alert the user to the presence of important operating and maintenance (servicing) instructions in the literature accompanying the appliance.

For Canada

This Class A digital apparatus complies with Canadian ICES-003.

For U.S.A.

NOTE: This equipment has been tested and found to comply with the limits for a Class A digital device, pursuant to Part 15 of the FCC Rules. These limits are designed to provide reasonable protection against harmful interference when the equipment is operated in a commercial environment. This equipment generates, uses, and can radiate radio frequency energy and, if not installed and used in accordance with the instruction manual, may cause harmful interference to radio communications.

Operation of this equipment in a residential area is likely to cause harmful interference in which case the user will be required to correct the interference at his own expense.

FCC Caution: To assure continued compliance, (example - use only shielded interface cables when connecting to computer or peripheral devices). Any changes or modifications not expressly approved by the party responsible for compliance could void the user's authority to operate this equipment.

The serial number of this product may be found on the surface of the unit.

You should note the serial number of this unit in the space provided and retain this book as a permanent record of your purchase to aid identification in the event of theft.

Model No. \_\_\_\_\_

Serial No. \_\_\_\_\_

**WARNING:**

- This apparatus must be earthed.
- To prevent fire or electric shock hazard, do not expose this apparatus to rain or moisture.
- The apparatus should not be exposed to dripping or splashing and that no objects filled with liquids, such as vases, should be placed on the apparatus.
- All work related to the installation of this product should be made by qualified service personnel or system installers.
- The connections should comply with local electrical code.

# Important Safety Instructions

- 1) Read these instructions.
- 2) Keep these instructions.
- 3) Heed all warnings.
- 4) Follow all instructions.
- 5) Do not use this apparatus near water.
- 6) Clean only with dry cloth.
- 7) Do not block any ventilation openings. Install in accordance with the manufacturer's instructions.
- 8) Do not install near any heat sources such as radiators, heat registers, stoves, or other apparatus (including amplifiers) that produce heat.
- 9) Do not defeat the safety purpose of the polarized or grounding-type plug. A polarized plug has two blades with one wider than the other. A grounding type plug has two blades and a third grounding prong. The wide blade or the third prong are provided for your safety. If the provided plug does not fit into your outlet, consult an electrician for replacement of the obsolete outlet.
- 10) Protect the power cord from being walked on or pinched particularly at plugs, convenience receptacles, and the point where they exit from the apparatus.
- 11) Only use attachments/accessories specified by the manufacturer.
- 12) Use only with the cart, stand, tripod, bracket, or table specified by the manufacturer, or sold with the apparatus. When a cart is used, use caution when moving the cart/apparatus combination to avoid injury from tip-over.



- 13) Unplug this apparatus during lightning storms or when unused for long periods of time.
- 14) Refer all servicing to qualified service personnel. Servicing is required when the apparatus has been damaged in any way, such as power-supply cord or plug is damaged, liquid has been spilled or objects have fallen into the apparatus, the apparatus has been exposed to rain or moisture, does not operate normally, or has been dropped.

## Limitation of Liability

THIS PUBLICATION IS PROVIDED "AS IS" WITHOUT WARRANTY OF ANY KIND, EITHER EXPRESS OR IMPLIED, INCLUDING BUT NOT LIMITED TO, THE IMPLIED WARRANTIES OF MERCHANTABILITY, FITNESS FOR ANY PARTICULAR PURPOSE, OR NON-INFRINGEMENT OF THE THIRD PARTY'S RIGHT.

THIS PUBLICATION COULD INCLUDE TECHNICAL INACCURACIES OR TYPOGRAPHICAL ERRORS. CHANGES ARE ADDED TO THE INFORMATION HEREIN, AT ANY TIME, FOR THE IMPROVEMENTS OF THIS PUBLICATION AND/OR THE CORRESPONDING PRODUCT (S).

## Disclaimer of Warranty

IN NO EVENT SHALL MATSUSHITA ELECTRIC INDUSTRIAL CO., LTD. BE LIABLE TO ANY PARTY OR ANY PERSON, EXCEPT FOR REPLACEMENT OR REASONABLE MAINTENANCE OF THE PRODUCT, FOR THE CASES, INCLUDING BUT NOT LIMITED TO BELOW:

- (1) ANY DAMAGE AND LOSS, INCLUDING WITHOUT LIMITATION, DIRECT OR INDIRECT, SPECIAL, CONSEQUENTIAL OR EXEMPLARY, ARISING OUT OF OR RELATING TO THE PRODUCT;
- (2) PERSONAL INJURY OR ANY DAMAGE CAUSED BY INAPPROPRIATE USE OR NEGLIGENT OPERATION OF THE USER;
- (3) UNAUTHORIZED DISASSEMBLE, REPAIR OR MODIFICATION OF THE PRODUCT BY THE USER;
- (4) INCONVENIENCE OR ANY LOSS ARISING WHEN IMAGES ARE NOT DISPLAYED, DUE TO ANY REASON OR CAUSE INCLUDING ANY FAILURE OR PROBLEM OF THE PRODUCT;

- (5) ANY PROBLEM, CONSEQUENTIAL INCONVENIENCE, OR LOSS OR DAMAGE, ARISING OUT OF THE SYSTEM COMBINED BY THE DEVICES OF THIRD PARTY;
- (6) ANY CLAIM OR ACTION FOR DAMAGES, BROUGHT BY ANY PERSON OR ORGANIZATION BEING A PHOTOGENIC SUBJECT, DUE TO VIOLATION OF PRIVACY WITH THE RESULT OF THAT SURVEILLANCE-CAMERA'S PICTURE, INCLUDING SAVED DATA, FOR SOME REASON, BECOMES PUBLIC OR IS USED FOR THE PURPOSE OTHER THAN SURVEILLANCE.

## Preface

Panasonic's WV-CW484 series cameras (WV-CW484F/WV-CW484S/WV-CW484FK/WV-CW484SK) introduce high picture quality by use of Super-Dynamic 1/3 inch CCD and digital signal processing LSIs.

- WV-CW484F: This is a model with x2 varifocal lens. Mounting bracket and ceiling mount bracket are optional.
- WV-CW484S: This is a model with x2 varifocal lens. Mounting bracket is supplied, but ceiling mount bracket are optional.
- WV-CW484FK: Lens, mounting bracket, and ceiling mount bracket are optional.
- WV-CW484SK: Lens is optional. Mounting bracket is supplied, but ceiling mount bracket are optional.

## Features

- Super Dynamic 3: 128x with zone-free brightness detection
- High sensitivity: 0.16 lx {0.016 footcandle} at F1.4 in B/W mode, 1.5 lx {0.15 footcandle} at F1.4 in color mode  
With the optional Dome Cover WV-CW4C, 0.08 lx {0.008 footcandle} in B/W mode and 0.6 lx {0.06 footcandle} in color mode become available.
- Auto nighttime switching to Black and White Mode  
The camera can be configured to switch to the black and white mode automatically under low light conditions for clear images, even at night.
- High resolution: 540 TV lines typical, 520 TV lines minimum
- Sensitivity enhancement: Up to 10x AUTO/32x FIX
- Synchronization: VD2/ LINE-LOCK/INTERNAL
- Auto-Back-Focus (flange-back (back focal) length adjustment): 1-push adjustment (local/remote), manual adjustment (local/remote), automatic adjustment at BW/CL transition  
Setup using an optional system controller is also available.
- Light control: ALC
- Miscellaneous: Privacy zone setting, Video motion detection, etc.

# CONTENTS

Important Safety Instructions .....	3
Limitation of Liability .....	4
Disclaimer of Warranty .....	4
Preface .....	5
Features .....	5
Precautions .....	7
Major Operating Controls and Their Functions .....	10
Lens Mounting (WV-CW484FK, CW484SK) .....	12
Installations .....	13
Image Adjustment .....	21
Connections .....	23
Flange-back (Back Focus) Adjustment .....	26
About Setup Menus .....	27
Setting Procedures .....	31
Troubleshooting .....	45
Specifications .....	47
Optional Accessories .....	48
Standard Accessories .....	48
Optional Accessories .....	48

# Precautions

## **This apparatus has no power switch.**

Power is supplied from an external 12 V DC/24 V AC power-supply device. Refer to service personnel for how to turn on/off the power.

## **To keep on using with stable performance**

- Parts of this product may deteriorate and it may shorten lifetime of this product when using in locations subject to high temperatures and high humidity. Do not expose the product to direct heat such from a heater.
- Use the appliance at temperature within  $-10^{\circ}\text{C}$  to  $+50^{\circ}\text{C}$   $\{14^{\circ}\text{F} - 122^{\circ}\text{F}\}$  and humidity below 90 %. (When using the appliance without turning the power off) With the optional Heater Unit WV-CW4H, this apparatus can be used at temperature within  $-30^{\circ}\text{C}$  to  $+50^{\circ}\text{C}$   $\{-22^{\circ}\text{F}$  to  $122^{\circ}\text{F}\}$  and humidity below 90 %.

## **Do not drop metallic parts through slots.**

This could permanently damage the apparatus. Turn the power off immediately and contact qualified service personnel for service.

## **Do not rub the edges of metal parts with your hand.**

Failure to observe this may cause injury.

## **Do not attempt to disassemble the camera.**

To prevent electric shock, do not remove screws or covers.

There are no user-serviceable parts inside. Ask qualified service personnel for servicing.

## **Handle the camera with care.**

Do not abuse the camera. Avoid striking, shaking, etc. The camera could be damaged by improper handling or storage.

## **Do not touch the dome cover with your bare hands.**

A dirty dome cover causes deterioration of picture quality.

## **Do not aim the apparatus at strong light sources.**

A light source such as a spot light causes a blooming (light bleeding) or a smear (vertical lines).

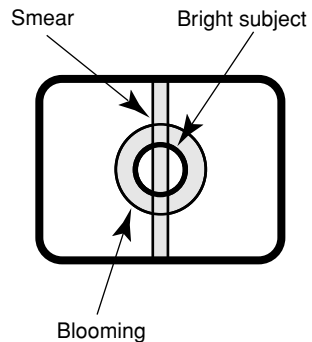

## **Cleaning the camera body**

Turn the power off when cleaning of the camera. Use a dry cloth to clean the camera.

Do not use strong abrasive detergent when cleaning the camera body. When the dirt is hard to remove, use a mild detergent and wipe gently. Then, wipe with a dry cloth.

Otherwise, it may cause discoloration. When using a chemical cloth for cleaning, read the caution provided with the chemical cloth product.

**Do not use strong or abrasive detergents when cleaning the camera body.**

Use a dry cloth to clean the camera when dirty. When the dirt is hard to remove, use a mild detergent and wipe gently. Then wipe off the remaining detergent with a dry cloth.

**About the dehumidifying device**

- The camera has dehumidifying device to keep the inside at low moisture level, preventing condensation and quickly dissipating dew if produced.
- Dew may be produced depending on the conditions of temperature, humidity, winds, and rain, and it may take time to dehumidify.
- Never seal the surfaces of the dehumidifying device.

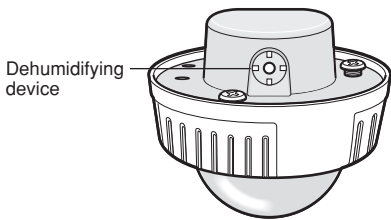

**Turn the circuit breaker off which supplies the camera with the power when abnormal conditions are encountered.**

**Observe the following for installation.**

- This apparatus is designed to be installed under eaves. Install this apparatus under eaves to avoid direct sunlight.
- If this apparatus is installed outdoors without eaves, ensure the same circumstances as being under eaves.

**Avoid installing in the following locations.**

- Locations where a chemical agent is used such as a swimming pool
- Locations subject to steam and oil smoke such as a kitchen
- Locations near flammable gas or vapor
- Locations where radiation or x-ray emissions are produced

- Locations subject to strong magnetic field or radio waves
- Locations where corrosive gas is produced
- Locations where it may be damaged by briny air such as seashores
- Locations where the temperature is not within  $-10^{\circ}\text{C}$  -  $+50^{\circ}\text{C}$  { $14^{\circ}\text{F}$  -  $122^{\circ}\text{F}$ }.
- Locations subject to vibrations (This product is not designed for on-vehicle use.)

**Installing place**

Contact your dealer for assistance if you are unsure of an appropriate place in your particular environment.

Make sure that the installation area is strong enough to hold the camera, such as a concrete ceiling.

When the installation area is not strong enough, reinforce and strengthen it or use Mounting Bracket WV-Q114 (option) or Ceiling Mount Bracket WV-Q166 (option).

**Do not install the camera in a humid or dust-laden environment.**

Otherwise, lifetime of the internal parts may be shortened.

**Radio interference**

When the camera is used near TV/radio antenna, strong electric field or magnetic field (near a motor or a transformer), images may be distorted and noise sound may be produced.

**Mounting screws**

Only the fixing screws are provided to fix the camera with the provided mounting bracket. It is necessary to procure screws or bolts to mount the camera. Prepare them according to the material and strength of the area where the camera is to be installed. The screws and bolts must be tightened with an appropriate tightening torque according to the material and strength of the installation area.



**Consumable parts**

Contact your dealer for replacement of the following part when the time comes:

Cooling fan needs replacement after around 30 000 hours of operation.

**Do not operate the camera beyond the specified temperature, humidity or power source ratings.**

Use the camera at temperatures within  $-10^{\circ}\text{C}$  to  $+50^{\circ}\text{C}$  ( $14^{\circ}\text{F}$  -  $122^{\circ}\text{F}$ ), and humidity below 90 %. The input power source is 24 V AC or 12 V DC.

# Major Operating Controls and Their Functions

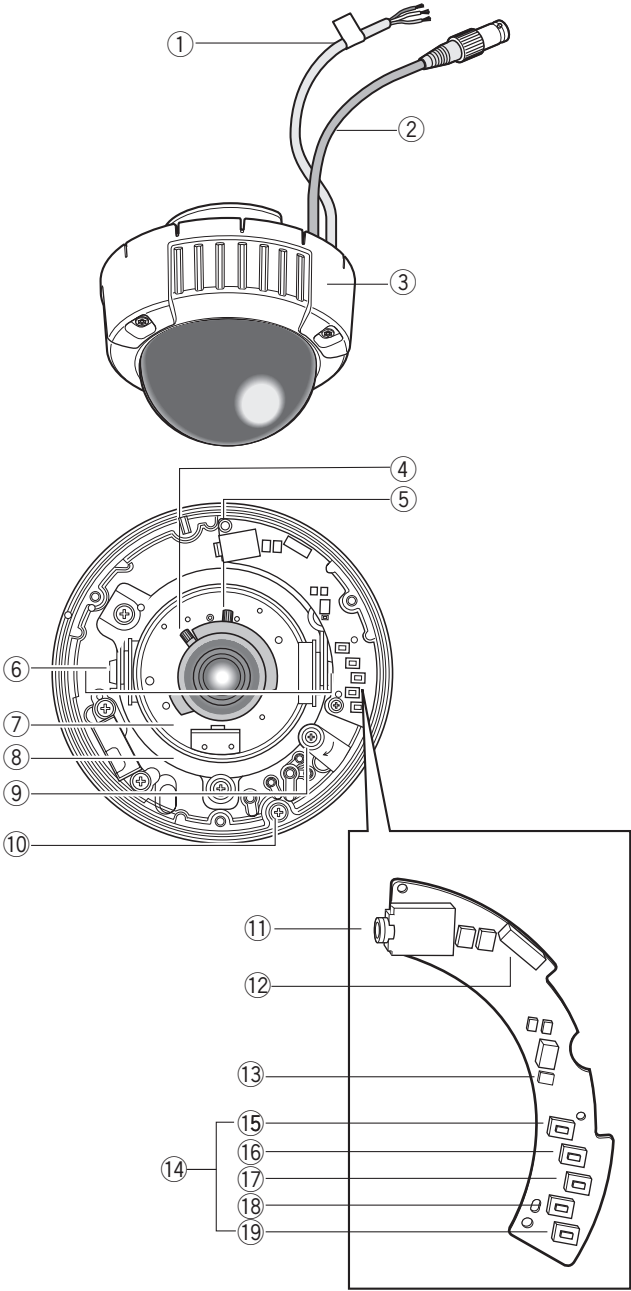

① **Power cable (12 V DC or 24 V AC)**

**Cautions:**

1. Connect to 12 V DC (10.5 - 16 V) or 24 V AC (19.5 V - 28 V) class 2 power supply only. Make sure to connect the grounding lead to the GND terminal when the power is supplied from a 24 V AC power source.
2. To prevent fire or electric shock hazard, use a UL listed cable (VW-1, style 1007) for the Input Terminal.

② **Video output cable with BNC connector**

Connects with the video connector of the monitor.

③ **Dome cover**

④ **Focus lock lever (WV-CW484F, WV-CW484S)**

Fixes the focus position.

⑤ **Zoom lock lever (WV-CW484F, WV-CW484S)**

Fixes the zoom position.

⑥ **Tilting lock screw**

Fixes the tilting position.

⑦ **Azimuth (Angle adjuster)**

Shoots in a straight-angle field of view when aiming at an object in a slanting direction even if the tilt angle has been set.

⑧ **Panning table**

Adjusts the panning angle of the camera.

⑨ **Panning lock screw**

Fixes the panning position.

⑩ **Camera lock screw**

Fixes the camera and camera attachment.

⑪ **Monitor output Jack (3.5 diam. mini jack)**

Connects the LCD monitor and such devices with 3.5 diam. 2-pole L-type plug for checking images.

⑫ **Optional heater connector (6 pin female)**

When an optional heater unit is installed in the camera, the harness exiting from the unit will be connected to this.

⑬ **LED indicator**

Shows the ABF status.

⑭ **Operation buttons**

⑮ **SET button [(SET), ABF2/MENU]**

Activates an item selected in the setup menu. Refer to p. 18 for details on the [ABF2] button.

⑭ **DOWN button [(DOWN), ABF1]**

Moves the cursor downward and selects items in the setup SET UP menu.

⑮ **UP button (UP)**

Moves the cursor upward and selects items in the setup menu.

⑮ **LEFT button [(LEFT), NEAR]**

Moves the cursor to the left, selects the mode and adjusts some levels.

⑮ **RIGHT button [(RIGHT), NEAR]**

Moves the cursor to the right, selects the mode and adjusts some levels.

## Lens Mounting (WV-CW484FK, CW484SK)

1. Before mounting the lens, remove the protection sheet from the camera.
2. Mount the optional lens to the camera by turning the lens clockwise.

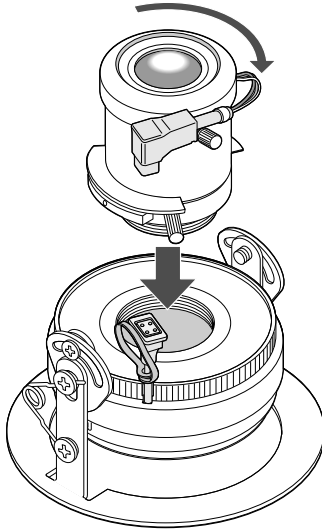

3. Insert the connector of lens into the connector of camera, and bind the connectors with the fixing band.

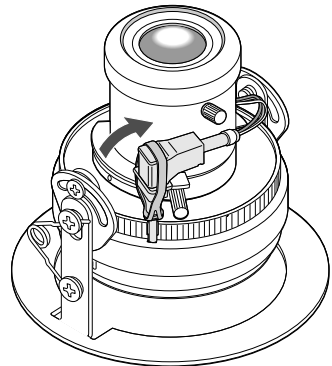
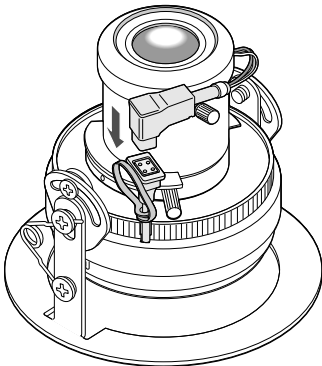

# Installations

The following installation should be made by qualified service personnel or system installers.

## Important:

- Prepare four fixing screws to be used to mount the provided camera attachment according to the material of the area where the attachment is to be installed.  
Recommended tightening torque is as follows.  
M4: 1.6 N·m {16 kgf·cm}
- Do not use wood screws to fix the camera mounting bracket (option) since they are not strong enough to support the weight of the camera and the bracket.
- When using the provided camera attachment, make sure that either of the arrow marks faces upward.
- When the installation area is not strong enough, reinforce and strengthen it or use Mounting Bracket WV-Q114 (option) or Ceiling Mount Bracket WV-Q166 (option).
- Required pull-out capacity of a single screw/bolt is 196 N {20 kgf} or more.
- When using an optional mounting bracket, refer to the operating instructions of the bracket in use.

## ■ Installations

### ● Using a Junction Box

Secure the provided camera attachment to the two gang junction box (4 in. x 4 in.) built in a wall or ceiling.

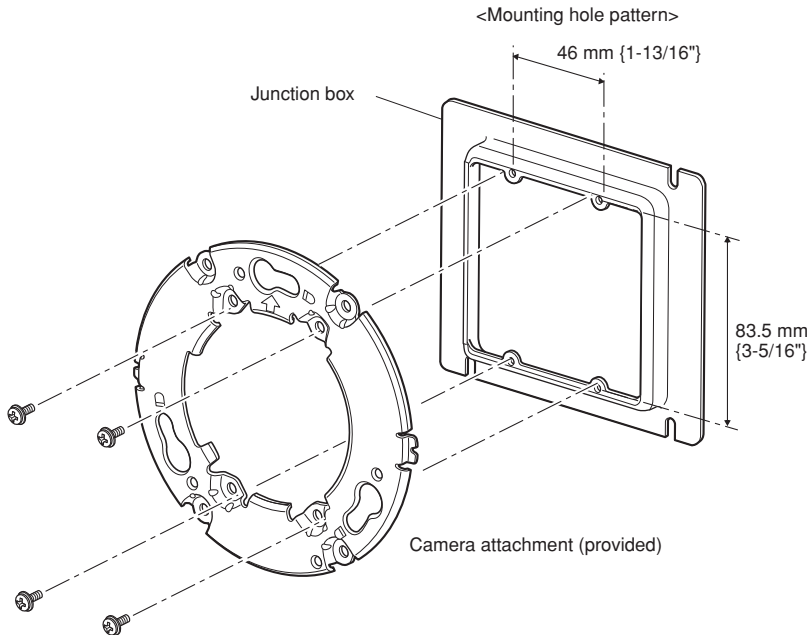

## ● Using Mounting Bracket WV-Q114 (Option)

- Secure the optional camera mounting bracket to wall or ceiling, and fix the provided camera attachment to the mounting bracket. (Refer to the following figures.)  
Verify the camera attachment and mounting bracket are mounted firmly after screwing them.
- When routing cables sideways or through the wall/ceiling, the mounting bracket is used.
- When routing cables sideways, open the sideways cable exit unscrewing the lid by use of a hexagon wrench. Screw the detached lid to the cable access hole on the bottom of the bracket.
- Make sure that either of the arrow marks faces upward.

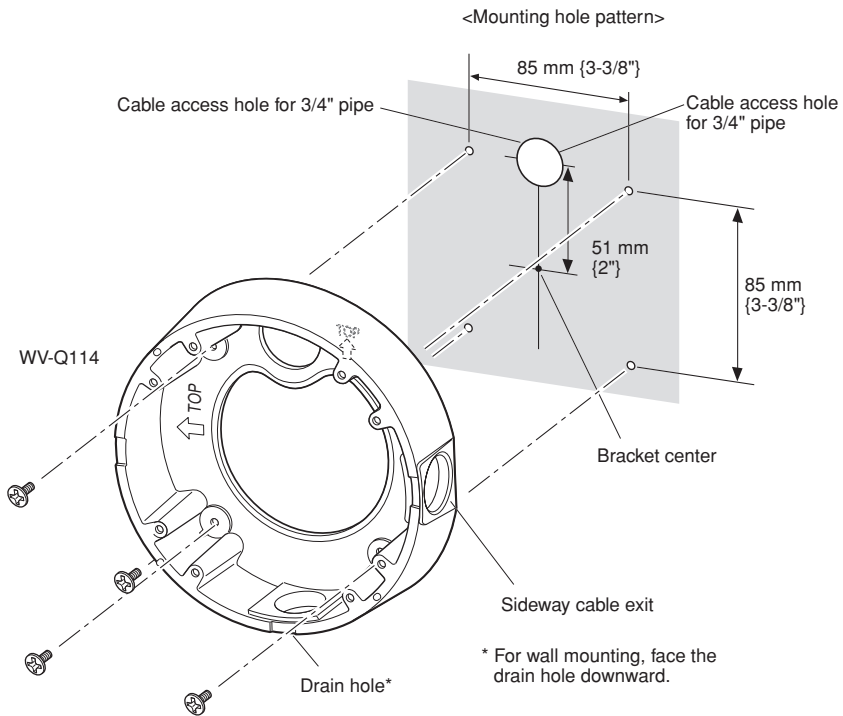

<Fixing the camera attachment to the mounting bracket>

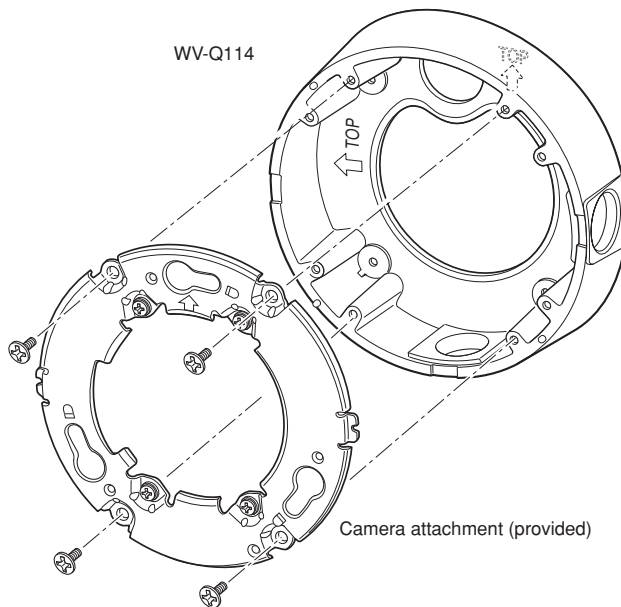

## ■ How to mount the camera

1. Connect the power cable and the BNC plug of the video output cable. (Refer to p. 23 Connections.)
2. Secure the camera with four attachment fixing screws.

### <Using a Junction Box>

3. Fit the protrusion at the rear of camera unit in the dent of camera attachment.

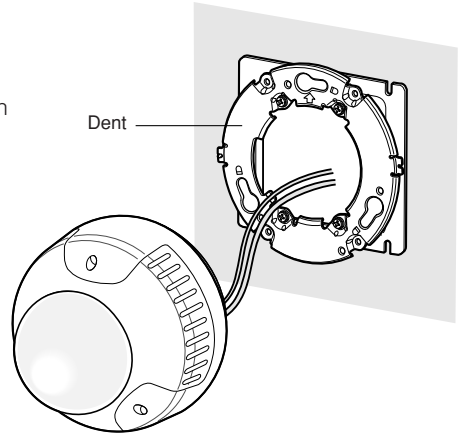

4. Hook the rear screws on the screw holes of camera attachment, and turn the camera unit clockwise to fix the camera unit and camera attachment.

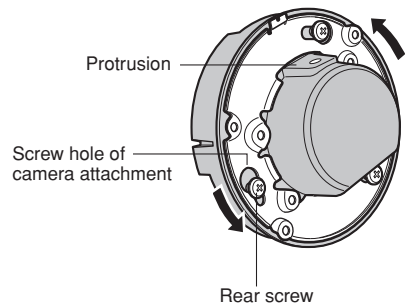

### <Using Mounting Bracket WV-Q114 (Option)>

3. Fit the protrusion at the rear of camera unit in the dent of camera attachment.

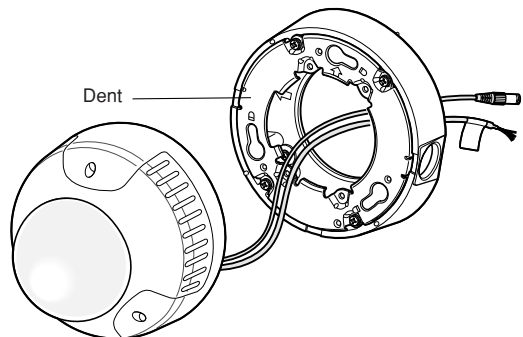



- Hook the rear screws on the screw holes of camera attachment, and turn the camera unit clockwise to fix the camera unit and camera attachment.

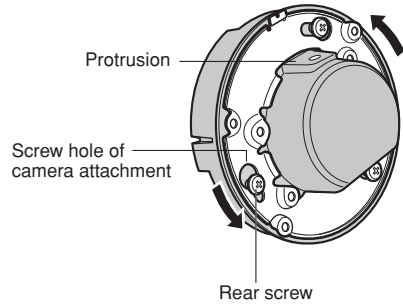

- Remove the dome cover from the main body by loosening the three dome cover mounting screws. The dome cover is fixed with tamper-proof screws. Loosen the three dome cover mounting screws by using the provided bit for tamper-proof screw.

**Note:** Perform the same procedure when replacing the optional dome cover with WV-CW4C.

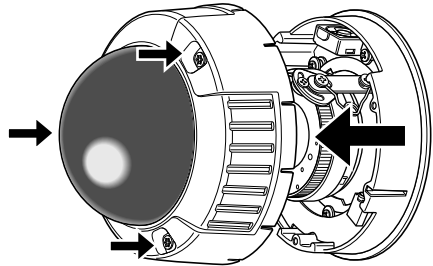

- Remove the red-colored screw for transport protection with a Phillips screw driver.

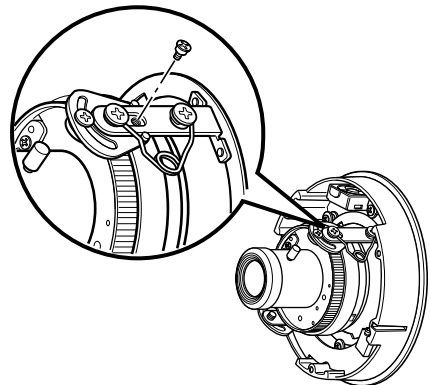

7. Secure the camera unit to the bracket with the camera lock screw.  
(The illustration describes an example using a junction box.)

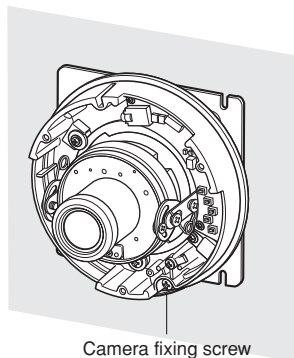

8. Adjust the camera. (Refer to p. 21.)
9. Attach the dome cover to the camera.  
Firmly tighten the three tamper-proof screws.  
(Recommended torque 0.78 N·m  
{0.08 kgf·m})

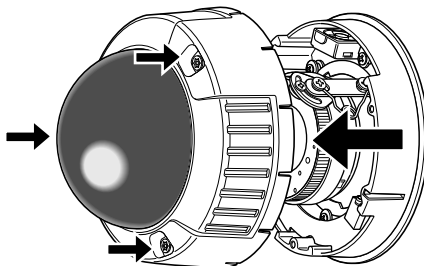

---

**Notes:**

- Defocus may be caused by the reinstalled dome cover. When using a system controller, adjust the back focus on the setup menu after attaching the dome cover.
- When not using a system controller, back focus adjustment is available by using the [ABF2] button after attaching the dome cover.
  - ① Press the [ABF2] button. The LED indicator will start blinking.
  - ② While the LED indicator is blinking (for around 3 minutes), attach the dome cover to the camera.
  - ③ When the LED indicator changes to steady light, back focus will be adjusted automatically.
  - ④ After the back focus is adjusted, the LED indicator will go out.

**Notes:**

- Do not aim the camera to objects continuously moving.
  - If the LED indicator blinks again after changing to steady light, back-focus adjustment may have failed. In this case, check the back-focus on the LCD monitor. To adjust the back-focus again, perform Step 1 to 3 again.
-

## ■ Waterproof Process

- When routing cables sideway using Mounting Bracket WV-Q114 (option) or installing the camera under eaves, apply waterproof process to the cable and relevant portions.
- The cables are not waterproofed. Provide water sealing for the tube ends and the portions between cable cores as well as connecting portions.
- The use of vinyl tape or other tapes instead of the butyl tape may cause water absorption from a gap and finally condensation and water leakage.

## ● Waterproof processing of cable connection

Surely use the provided butyl tape. (Do not use a sealing material on those parts.)

1. Connect and tape the power cables.
2. Bind the power cables together with the tape.
3. Tape the BNC-BNC joint.

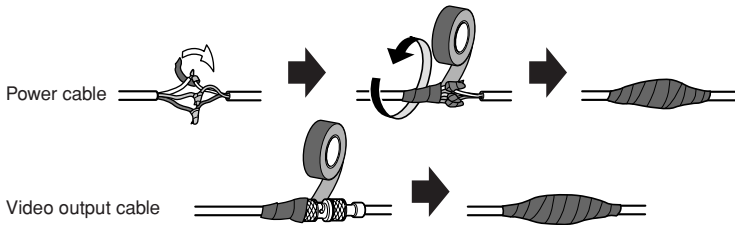

## Winding the provided butyl tape

Stretch the tape to about twice its original length as shown and wind the tape around the cables. The tape will not harden if the tape is not stretched enough.

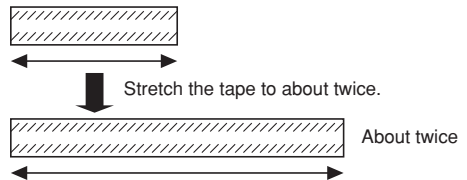

---

**Notes:**

- Surely attach a pipe fitting to the bracket to avoid exposing the cables. Otherwise, cable deterioration resulting from cable exposure may cause a short circuit.

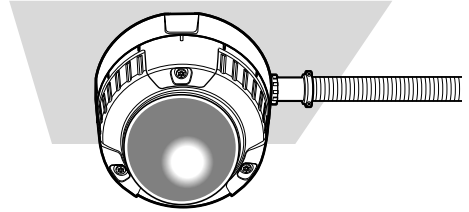

- Run the conduit downward or pull the conduit out of the side of the bracket. When pulling the conduit out of the side of the bracket, run the conduit downward once, and upward.

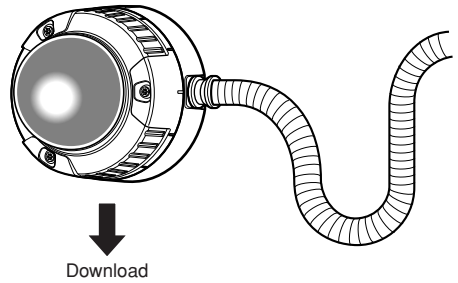

- For wall installation, face the drain hole downward and do not block the hole. When rain water is accumulated in the bracket, the water blocks the desiccant agent and air membrane permeation on the rear of the camera, which may cause water leakage.

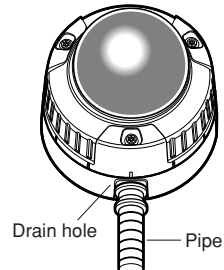

# Image Adjustment

You can manually adjust the pan/tilt/azimuth angles, focus, and zoom while observing the connected monitor.

## Notes:

- When connecting an LCD monitor to adjust the camera images, use an L-type mini plug. Straight type plugs are not available.
- Do not hold the camera by lens unit to adjust panning, tilting, or azimuth.
- The video output to the BNC will be interrupted while an LCD monitor is connected to the monitor output jack.
- While an LCD monitor is connected to the monitor output jack, ELC (Electric Light Control) becomes effective to obtain a proper focus. During focus adjustment, blooming or smear on highlighted objects may be caused. However, ALC (Automatic Light Control) is effective during the normal use, and blooming or smear is reduced.
- Adjust zoom and focus after adjusting panning and tilting. (Refer to Step 3 and 4.)

1. Connect an LCD monitor to the monitor output jack.

2. Pan/tilt/azimuth adjustment

- Loosen the three screws locking the pan and tilt tables.
- Pan and tilt the table to aim the camera at what you need to watch.
- Turn the azimuth adjuster to obtain a level image.
- Tighten the three screws after adjusting.

3. Zoom

- Unlock the zoom lever.
- Move the lever to adjust the zoom.
- Lock the lever.

4. Focus

- Unlock the focus lever.
- Move the lever to adjust the focus.
- Lock the lever.

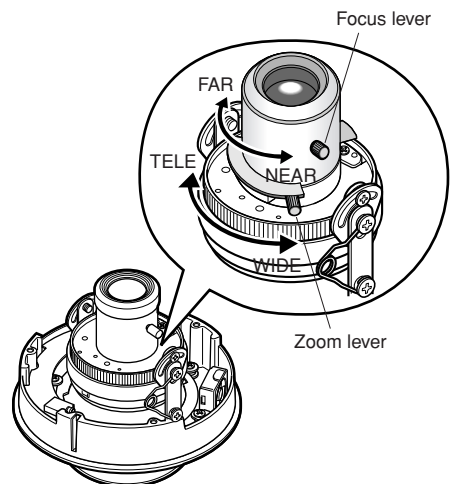
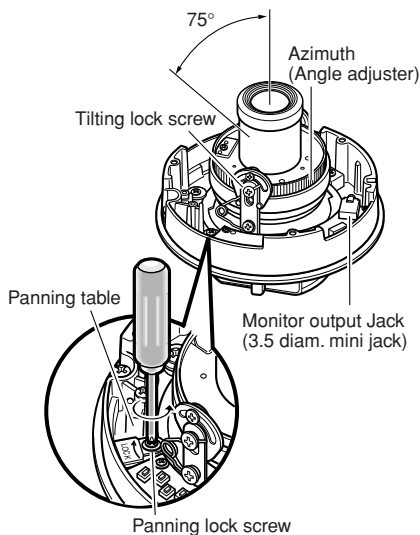

5. Aim the camera at the targeting objects and if applicable adjust the zoom angle.
6. Press the [DOWN] button.
  - The LED indicator will light up, and a bar graph with "I" cursor and INDICATOR (4-digit number) will be overlaid on the camera picture.
  - Back focus will be automatically adjusted.

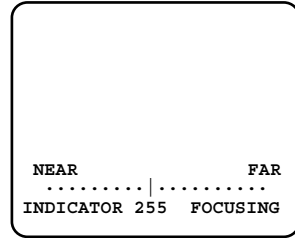

7. If needed, perform manual adjustment using the L and R buttons to obtain the best focus on the targeted object while observing the picture. See INDICATOR on the monitor for reference.

---

**Notes:**

- The bar graph will disappear if no operation is performed for around 10 seconds.
  - When changing the angular field of view, move the zoom lever and focus lever again for adjustment.
- 

**Zoom/focus adjustment**

When shooting an object using an AF lens, the first adjusted focus may be out-of-focus depending on the focal depth of the lens in use. In this case, focus on a darker object with the aperture open to prevent out-of-focus.

When "ABF" is selected for "BACK-FOCUS" on the SETUP menu (refer to p. 41), the camera can automatically focus on a subject with the best available conditions even when the illumination changes.

- Under near-infrared light, the focus may be slightly out-of-focus than under visible light. When the "BACK-FOCUS SETUP" page is displayed and "AUTO" or "PRESET" is selected for "C/L" ↔ "B/W" using the operation buttons on the camera, the camera can focus on subjects both under near-infrared light and under visible light. (However, the camera will not change the focus according to the illumination change when the focus had been adjusted once.)

**<How to use a varifocal lens>**

Before adjusting the varifocal lens, reset the flange-back length position to the default position for the CS-mount (by simultaneously pressing the [LEFT] and [RIGHT] buttons for 2 seconds or more, or by simultaneously pressing the [LEFT] and [RIGHT] buttons after pressing the [SET] button when the cursor is on "MANUAL-ADJ" on the "BACK-FOCUS SETUP" page.

# Connections

**Caution:** ONLY CONNECT THIS TO 24 V AC or 12 V DC CLASS 2 POWER SUPPLY. Be sure to connect the grounding lead to the GND terminal.

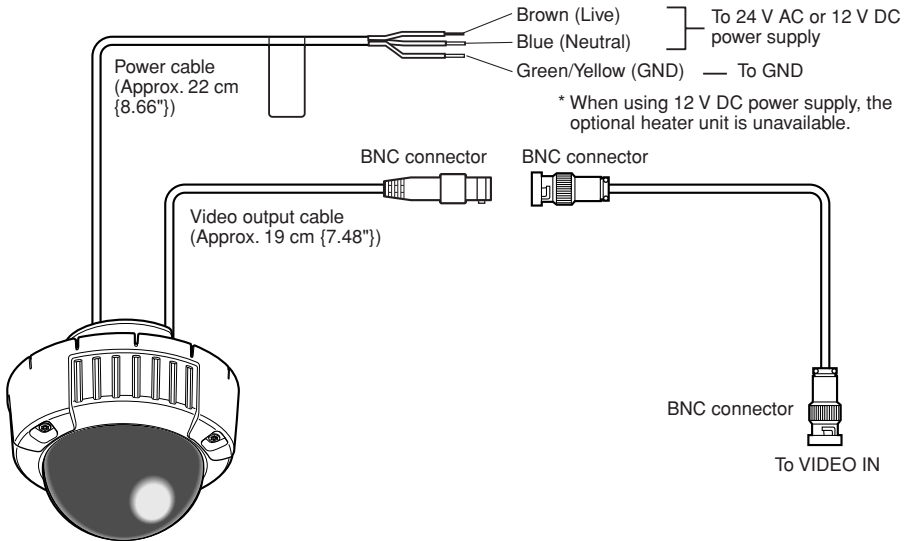

## ● Video Output Connection

Connect the video output connector to the monitor or other system device with the procured coaxial cable. The maximum extensible length is shown in the table.

Type of coaxial cable		RG-59/U (3C-2V)	RG-6/U (5C-2V)	RG-11/U (7C-2V)	RG-15/U (10C-2V)
Recommended maximum cable length	m	250	500	600	800
	ft	825	1 650	1 980	2 640

## ● Power Connection

### Precaution:

The following connections should be made by qualified service personnel or system installers in accordance with NEC 725-51.

### • Wire Colors & Functions

#### Camera power cable

Wire Color	24 V AC	12 V DC
Brown	24 V AC (L)	Positive
Blue	24 V AC (N)	Negative
Green/Yellow	To GND	

### Cautions:

- Be sure to connect the GND (grounding) lead of the camera and grounding terminal of the power supply when using a 24 V AC power source.
- Shrinking the cable-entry seal is a one-time procedure. Do not shrink the cable-entry seal until it has been ascertained that unit is functioning.  
CONNECT THIS TO 24 V AC or 12 V DC CLASS 2 POWER SUPPLY ONLY.
- To prevent fire or electric shock hazard, the UL listed wire VW-1 style 1007 should be used for the cable for Input Terminals.
- Do not use a transformer larger than 10 VA.

## • Cable Length and Wire Gauge

### 24 V AC

The recommended cable length and thickness are shown in the table for reference. The voltage supplied to the power terminals of the camera should be within 19.5 V AC and 28 V AC.

Recommended wire gauge for 24 V AC line.

Copper wire size (AWG)		#24 (0.22 mm <sup>2</sup> )	#22 (0.33 mm <sup>2</sup> )	#20 (0.52 mm <sup>2</sup> )	#18 (0.83 mm <sup>2</sup> )
Length of Cable (Approx.)	(m)	20	30	45	75
	(ft)	65	100	160	260

### 12 V DC

Use the formula below to calculate the power cable and power supply. The voltage supplied to the power terminals of the camera should be within 10.5 V DC and 16 V DC.

Resistance of copper wire [at 20 °C (68 °F)]

Copper wire size (AWG)	#24 (0.22 mm <sup>2</sup> )	#22 (0.33 mm <sup>2</sup> )	#20 (0.52 mm <sup>2</sup> )	#18 (0.83 mm <sup>2</sup> )
Resistance $\Omega$ /m	0.078	0.050	0.03	0.018
Resistance $\Omega$ /ft	0.026	0.017	0.010	0.006

$$10.5 \text{ V DC} \leq VA - 2(R \times I \times L) \leq 16 \text{ V DC}$$

L : Cable length (m) (ft)

R : Resistance of copper wire ( $\Omega$ /m) ( $\Omega$ /ft)

VA : DC output voltage of power supply unit

I : DC current consumption (A). See specifications.

**Note:** When using 12 V DC power supply, the optional heater unit is unavailable.



## ■ Optional Heater Unit WV-CW4H

### ● Introduction

Installing this heater unit enables the camera to operate in a low-temperature environment below  $-30^{\circ}\text{C}$   $\{-22^{\circ}\text{F}\}$ . The heater turns on automatically when the temperature inside the camera drops below  $+10^{\circ}\text{C}$   $\{50^{\circ}\text{F}\}$  and turns off when the temperature rises.

A small fan inside the unit will minimize condensation on the surface of the dome cover caused by changes in ambient temperature unless temperatures change too rapidly. The fan will stop when there is no possibility of condensation.

### Cautions:

- When using 12 V DC power supply, the optional heater unit is unavailable.
- Turning the heater on and off may disturb the camera images.
- When servicing, pay attention to high temperature on the surface of the heater unit. Disconnect the harness and wait until the heater unit cools.
- When you install and operate the camera in a low-temperature environment below  $-10^{\circ}\text{C}$   $\{14^{\circ}\text{F}\}$ , it may take time (around 30 minutes) for the inside of the camera to warm up. In such a case, wait around 30 minutes or more.

### ● Installation

1. Open the dome cover.
2. Place the heater unit in the camera and fix it with the supplied screw (x1).
3. Insert the harness (x1) into the heater unit connector of the camera.

**Note:** Attach the desiccant pack so that it does not block ventilation holes or hang over the top of the wall.

4. Attach the dome cover.

**Note:** Do not pinch the harness cable.

5. Connect the heater power cable of the camera. (Refer to p. 23 Connections.)

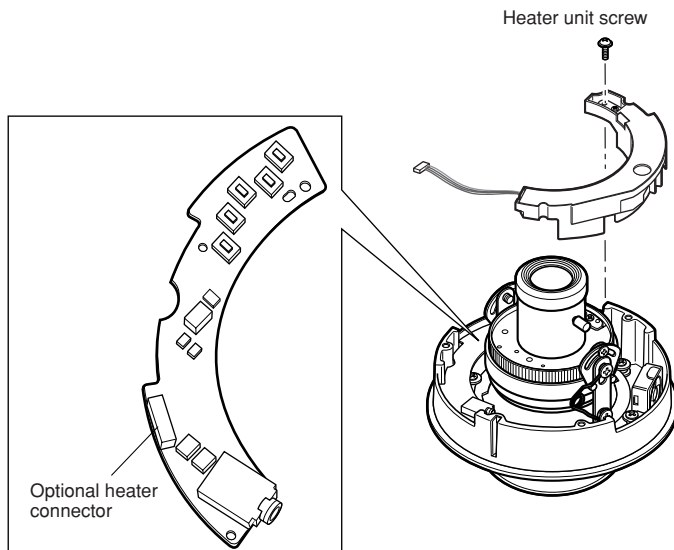

## Flange-back (Back Focus) Adjustment

This adjustment can be also performed on the setup menu. Refer to p. 41. Back-focus Setting for details.

**Important:** Do not use the ABF function for continuous or repetitive purposes (ex. auto-focus etc.). This function is to be used to correct defocus caused by switching between color and black - and - white when/after installing the camera.

### Hints

#### Before Back-focus Adjustment

- Adjustment procedures vary depending on the lens. Refer to the instructions included with the lens.
- Reset the back-focus by pressing the LEFT and RIGHT buttons simultaneously on the camera, and adjust the back-focus.
- Move the lens focus to the FAR-end when using a fixed-focal lens (lens focus adjustable type), and adjust the back-focus.

#### For Adjusting the Focus

- It is recommended that you lower the lighting for the object to be as dim as possible when adjusting the focus with an auto iris lens. This will make the iris open and will result in an accurate focus even though the lighting conditions vary. This may be slightly different from the best focus point in a specific lighting condition.
- Compared with cases under visible lights, using near-infrared lights may somewhat deviate the focus. It is recommended that you select AUTO or PRESET for C/L ← → B/W in the BACK-FOCUS SETUP menu to obtain a proper focus for each of visible and near-infrared lights.

#### For Using General Vari-focal Lenses

1. Aim at the objects 10 meters away or more to adjust the back-focus.
2. For 8x and 10x class lenses, set the zoom to the WIDE-end and the focus to the FAR-end, and then adjust the back focus.
3. For 2x and 3x class lenses, set the zoom to the TELE-end and the focus to the FAR-end, and then adjust the back focus.
4. Aim the camera at the targeted objects to place them in the center then coarsely adjust the zoom angle and the focus of the lens. Finally, perform adjustment of the back-focus in either ways of using ABF (automatically) or MANUAL-ADJ (manually).

**Note:** There may be lenses having an extended range in lens focus adjustment, except Panasonic lenses. When using such a lens, set the lens focus back appropriately from the applicable end position in the above step 2 and 3 depending on the lens, and then perform back-focus adjustment. The back-focus will not be properly adjusted if the lens focus is positioned into the extended range.

# About Setup Menus

Before operation, setup of this camera is required. On the setup menu, you can check current settings and perform settings to meet requirements.

The following is an example of setup procedure when LANGUAGE is set to ENGLISH.

## Settings items of the camera setup page

Setup item	Description	Reference pages
<b>CAMERA</b>	Configure the settings relating to camera operations	
CAMERA ID	The camera title can be edited and displayed on the screen.	31
ALC	Configure the light control method.	32
SHUTTER	Select the shutter speed.	33
AGC	Select the method of the gain adjustment.	34
SENS UP	Adjust the sensitivity.	34
SYNC	Configure the method of the synchronization.	35
WHITE BAL	Select the method of the white balance adjustment.	35
DNR	Configure the settings for the DNR (Digital Noise Reduction) function.	38
RESOLUTION	Select a horizontal resolution mode.	38
BW MODE	Configure the settings relating to the BW mode such as the settings for switching between the color mode and the BW mode.	38
PRIVACY ZONE	It is possible to mask a designated zone and as a privacy zone.	39
EL-ZOOM	Adjust the electronic zoom.	40
UPSIDE-DOWN	Select the upside down positioning of camera picture.	40
STABILIZER	Select "ON" or "OFF" to determine whether or not to use the image stabilizer to prevent shaky images.	40
<b>BACK-FOCUS</b>	Select the method of the flange-back (back focal) length adjustment and adjust the flange-back (back focal) length minutely.	41

<b>Setup item</b>	<b>Description</b>	<b>Reference pages</b>
<b>SPECIAL</b>		
CHROMA GAIN	Adjust the chroma level (color density).	42
AP GAIN	Adjust the aperture level.	43
PEDESTAL	Adjust the pedestal level (brightness).	43
HUE	Adjust the chroma phase.	43
PIX OFF	Correct image defects such as scratches.	43
CAMERA RESET	Reset the settings edited on the [Camera] tab to the default settings.	44
SER.NO.	Check the serial number of this camera.	44
<b>LANGUAGE</b>	Select the language to display the setup menu.	31

## ■ Basic operation

The following are descriptions of how to configure each setup item using the operation buttons (refer to p. 10) on the camera. Setup using an optional system controller is also available.

### Note:

The illustrations below are the examples to be displayed on a video monitor.

1. Hold down the [SET] button for around 2 seconds.

→ The top page will be displayed.

2. Move the cursor onto "END" by press the [UP] or [DOWN] button.

```
MODEL WV-CW484 SERIES
CAMERA 1
BACK-FOCUS 1
SPECIAL 1
LANGUAGE 1

END      SETUP DISABLE
```

3. Press the [SET] button after moving the cursor onto "SETUP" by pressing the [RIGHT] button.

→ The "DISABLE" indication will change into "ENABLE" and the settings will become editable.

```
MODEL WV-CW484 SERIES
CAMERA 1
BACK-FOCUS 1
SPECIAL 1
LANGUAGE 1

END      SETUP ENABLE
```

4. Move the cursor onto the desired setup item and press the [SET] button.

→ The setup page of the selected setup item will be displayed.

5. Configure the settings for each item.

**Select setup item:** Move the cursor by pressing the [UP] or [DOWN] button.

**Change the parameter:** Press the [LEFT] or [RIGHT] button.

**Display the detailed settings page of the setup item:** Press the [SET] button when the setup item with the [↕] mark is selected.

**Go back to the previous page:** Move the cursor onto "RET" and press the [SET] button.

**Go back to the top page:** Move the cursor onto "TOP" and press the [SET] button.

```
**CAMERA SETUP** 1/2
CAMERA ID   OFF 1
ALC         ALC 1
SHUTTER     OFF
AGC         ON(HIGH)
SENS UP     OFF
SYNC        INT
WHITE BAL   ATW1 1
MOTION DET  OFF
DNR         HIGH
RESOLUTION  HIGH
BW MODE 1
```

```
**CAMERA SETUP** 2/2
PRIVACY ZONE OFF
EL-ZOOM      OFF
UPSIDE-DOWN  OFF
STABILIZER   OFF
LENS         PANASONIC

RET  TOP  END
```

6. To exit from the SETUP menu and display images from the camera, move the cursor onto "END" and press the [SET] button.

---

**Notes:**

- To prevent erroneous operations, the "DISABLE" indication will always be displayed when the top page is displayed from the camera. To operate the SETUP menu, switch the "DISABLE" indication to the "ENABLE" indication first.
  - The cursor position will be displayed highlighted.
-

# Setting Procedures

First, select a language for menu display and camera ID display.

## Language Setup (LANGUAGE SETUP)

1. Select LANGUAGE on the top menu and press the [SET] button.  
→ The LANGUAGE SETUP menu opens.
2. Select a language. The default setting is English.

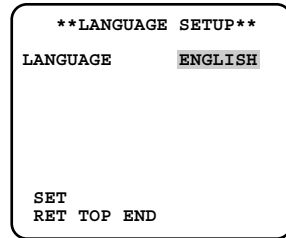

**Available languages:** ENGLISH, FRANÇAIS, DEUTSCH, ESPAÑOL, ITALIANO, РУССКИЙ, JAPANESE, CHINESE

3. Select SET on the menu and press the [SET] button.

## 1. Camera Identification Setting (CAMERA ID)

Assign a name to the camera using up to 16 characters to display it overlaying on the camera picture in the selected position.

**Note:** If you change the language selection after the assignment of camera ID, it will be erased.

1. On the CAMERA SETUP menu, select ON↓ or OFF↓ for CAMERA ID and press the [SET] button.

**ON↓:** Displays entered camera ID.

**OFF↓:** Does not display the ID.

→ The CAMERA ID menu opens.

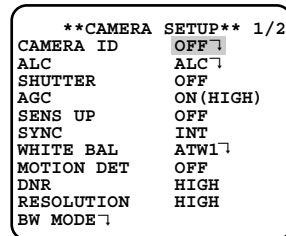

2. Select a character from the character area and press the [SET] button.

→ The selected characters are displayed in the editing area.

3. Repeat these procedures until all characters are entered.

- To enter a blank space, select SPACE and press the [SET] button.
- To replace a specific character in the editing area:

1. Move the cursor to the editing area and then move the pointer to the character to be replaced pressing the [LEFT] and [RIGHT] buttons.
2. Move the cursor to a candidate character in the character area and press the [SET] button.

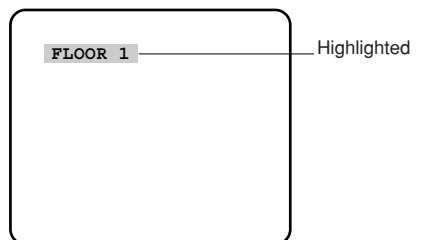
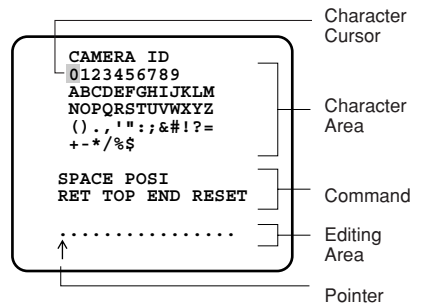

- To erase all characters of the camera ID, select RESET and press the [SET] button.  
**Note:** For Chinese language, up to 8 characters can be entered.

4. To specify the ID display position:

1. Select POSI and press SET.  
 → The entered camera ID will be highlighted on the screen.
2. Move it into the appropriate position and press SET.  
 → The position is determined and the screen will return to the CAMERA ID menu.

**Note:** Keep pressing any of [LEFT], [RIGHT], [UP], or [DOWN] button for a second or more to move the camera ID faster as necessary.

## 2. Light Control Mode Setting (ALC)

Select a light control mode depending on the lens type mounted. The default setting is ALC.

**ALC↓:** Is applicable to the auto iris lens. SUPER-D3 is available with this selection.

### 2-1. ALC Mode with SUPER-D3 ON

#### Super Dynamic 3 Function (SUPER-D3)

In the SUPER-D3 mode, more photometric weight is given to the center of the screen than to the edge where a bright backlight would most likely be located.

SUPER-D3 ON

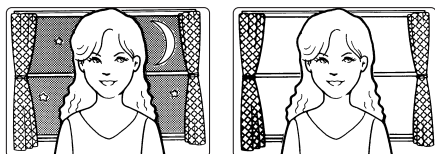

Nighttime

Daytime

SUPER-D3 OFF

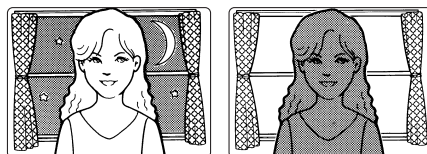

Nighttime

Daytime

**SUPER-D3 ON:** Enables SUPER-D3 to compensate backlight automatically.

**SUPER-D3 OFF:** Enables manual setting to compensate backlight.

#### Notes:

- When set to ON, the available parameters for SHUTTER and SENS-UP will be limited as shown on the next page.
- Set SUPER-D3 to OFF when noise in a bright portion, flickerings, or color deterioration are observed.

1. Move the cursor to ALC.  
 → The ALC CONT menu opens.
2. Select ON for SUPER-D3.
3. Adjust the video output level (LEVEL) by moving the "I" cursor. It may be better to adjust LEVEL slightly higher.

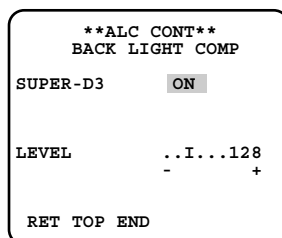



## 2-2. ALC Mode with SUPER-D3 OFF

1. Move the cursor to ALC on the CAMERA SETUP menu or select OFF for SUPER-D3 on the ALC CONT menu.

→ MASK SET↓ appears on the ALC CONT menu.

2. Select MASK SET and press SET.

→ The 48 mask areas appear overlaid on the camera picture with the blinking cursor in the upper left corner.

3. Move the cursor to an area where the backlight is bright and press SET to mask the area.

→ The masked area appears alternately white and blinking when the cursor is on the area, or it turns white when the cursor is on other areas.

4. To cancel masking, move the cursor to a masked area and press SET.

→ When masking of the area is cancelled, it changes from white to normal.

To cancel all the masking, press the [LEFT] and [RIGHT] buttons simultaneously for 2 seconds or more.

5. Repeat step 3 and 4 as necessary.

6. Press SET for 2 seconds or more.

→ The ALC CONT menu appears.

7. Adjust the video output level (LEVEL) by moving "I" cursor.

**Note:** If ON is selected for SUPER-D3, a shadow (black line) may appear at the boundary between the bright and the dim portions. This is a natural phenomenon and does not indicate trouble.

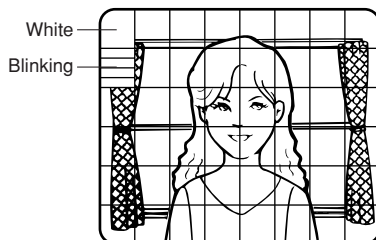
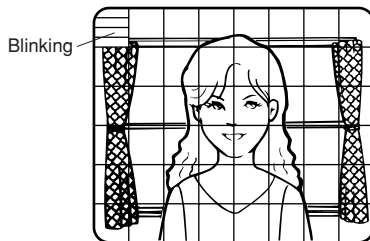
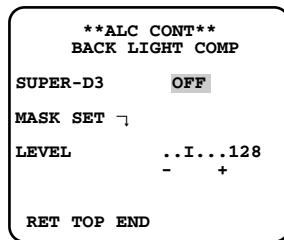

## 3. Shutter Speed Setting (SHUTTER)

Select a proper shutter speed when ALC is selected on the CAMERA SETUP menu. Selecting a faster speed will reduce blurring when objects quickly move. The default setting is OFF.

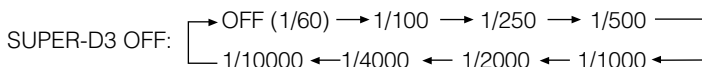

**Notes:**

- Only OFF is available when SUPER D3 is set to ON.
- When a faster speed is selected for the electronic shutter, the picture will generally become darker, and sometimes a smear (vertical stripes caused by bright objects) may appear.

#### 4. Gain Control Setting (AGC)

Select an automatic gain control mode. This setting raises the gain and brightens the image under low light conditions. The default setting is ON (HIGH).

**Available modes:** ON (HIGH / high), ON (MID / medium), ON (LOW / low), OFF

#### 5. Electronic Sensitivity Enhancement (SENS UP)

Select a proper enhancement rate when the camera is set to ALC mode. The higher rate you select, the brighter the picture will be. The default setting is OFF.

**AUTO:** Sets AGC to ON and adaptively raises the sensitivity up to the selected amplification rate, for example 10 times when set to X10 AUTO.

**FIX:** Raises the sensitivity fixedly to the selected rate.

**OFF:** Does not raise the sensitivity.

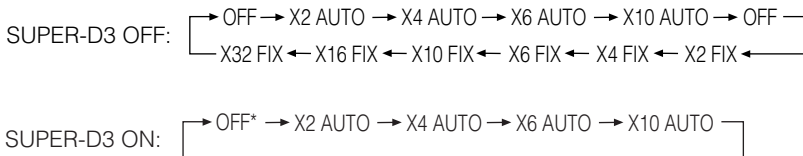

\* The factory default

**Notes:**

- OFF and AUTO are available when SHUTTER is set to 1/100.
- When setting SHUTTER to 1/100, perform the SHUTTER setting before the SENS UP setting.
- Some types of system controllers may not operate some of the SENS UP functions. If this happens, use the operation buttons on the camera.
- When you select AUTO for SENS UP and ON for SUPER-D3, the SENS UP function has priority so that the SUPER-D3 function is not activated automatically.
- While the SENS UP function is selected, noise, spots or a whitish phenomenon may appear in the picture when the sensitivity of the camera is increased. This is a normal phenomenon.
- Only when OFF, X2 FIX, or X2 AUTO is selected for sensitivity enhancement (SENS UP), It is possible to perform ABF adjustment or to select AUTO for C/L → B/W on the BACK-FOCUS SETUP menu. When a sensitivity rate other than X2 FIX or X2 AUTO is selected, use PRESET and FIX for C/L → B/W on the BACK-FOCUS SETUP menu.

## 6. Synchronization Setting (SYNC)

1. Select a sync mode.

**VD2:** Multiplexed vertical drive, highest priority

**LL:** Line-Lock, follows the phase of supplied AC power, 2nd priority

**INT:** Internal sync, lowest priority

### Notes:

- Selection is not available when VD2 is added to the camera. Selection from LL is available when the respective sync is added.
- When LL is selected, phase adjustment is required.

2. Line-Lock Vertical Phase Adjustment (V PHASE)

- Select LL and press SET.
- Prepare a dual-trace oscilloscope and supply it with the video output of the camera to be adjusted and that of the reference camera.
- Set the oscilloscope to the vertical rate and expand the V-sync portion.
- Select a proper COARSE phase from 16 steps (22.5 degrees/step) that makes the two video signals on the oscilloscope the closest.
- Select a proper FINE phase so that the two video signals on the oscilloscope come as close as possible.

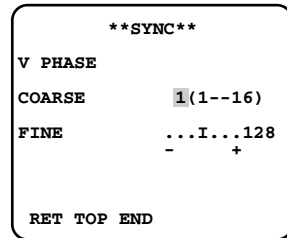

### Notes:

- Moving the "I" cursor across the +/- end will shift the FINE range.
- Press the [LEFT] and [RIGHT] buttons simultaneously to reset the V PHASE to the default (0 degree).
- Keep pressing the [LEFT] and [RIGHT] buttons for a second to move the "I" cursor faster if necessary.
- Spike noise if contained in the AC mains may disturb synchronization of LL.

## 7. White Balance Setting (WHITE BAL)

Select a mode for WHITE BAL on the CAMERA SETUP menu. The default is ATW1.

**ATW1:** Is automatically adaptable to the color temperatures of 2 700K - 6 000K.

**ATW2:** Is automatically adaptable to the use of sodium lamps (2 000K - 6 000K).

**AWC:** Is automatically adaptable to the color temperatures of 2 000K - 10 000K.

### Notes:

- When ATW1 or ATW2 is selected, no further operation is required.
- ATW1 and ATW2 do not appear on the setup menu of the system controller.
- Select AWC in the following cases: the color temperature is out of the 2 000K - 6 000K range, the scene contains mostly high color temperatures such as blue sky or sunset, or the scene is dim.
- When AWC is selected, the AWC setting is required.

## AWC Setting

1. Select AWC and press the [L] button.  
→ AWC will change to AWC → PUSH SW.
2. Press SET.  
→ PUSH SW will be highlighted while the AWC setting is performed.  
**Note:** If the white balance is not set, PUSH SW is being highlighted.
3. Press the [R] button.

## Manual Fine Adjustment

Perform fine adjustment as necessary.

1. Select WHITE BAL and press SET.  
→ Fine adjustment menu of ATW or AWC will open.
2. Adjust finely R (Red) and B (Blue) gain by moving the "I" cursor.

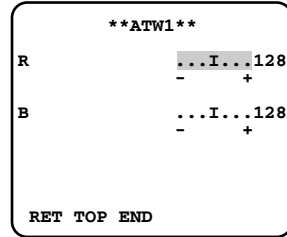

## 8. Motion Detection Setting (MOTION DET)

When a series of changes in pictures is detected, the camera outputs an alarm to the external device such as a disk recorder. The recorder will start recording the pictures.

1. Select a mode for MOTION DET on the CAMERA SETUP menu.  
The default setting is OFF.

**OFF:** Disables the alarm output.

**MODE1↓:** Outputs alarm when a series of motions is detected.

**MODE2:** Outputs alarm when a series of scene changes is detected.

→ The MODE 1 menu opens when you select MODE1 and press SET.

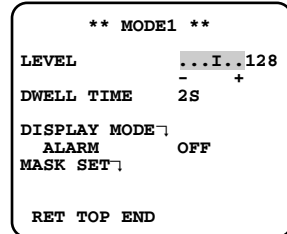

2. Adjust for LEVEL to optimize the sensitivity of detection.

3. Select a dwell time. The default is 2S.

**Available time (second):** 2, 5, 10, 30

The next detection will be performed after the set time elapses.

4. Select MASK SET and press SET.

→ A 48-split screen opens.

- Specify non-detection (mask) and detection areas in the same way as described earlier in 2-2 ALC Mode.
- Hold down SET for 2 seconds to return to the MOTION DET menu.

**Note:** Perform the setting of mask area after STABILIZER in the CAMERA SETUP menu is set to OFF.



5. Select ON or OFF for ALARM under DISPLAY MODE.

**ON:** Outputs an alarm

**OFF:** Does not output an alarm. This is applicable any of the following controllers are used:  
WV-RM70, WV-CU550 series, WV-CU161, WV-CU360, WV-CU650, WV-CU850, WV-CU950

6. Select DISPLAY MODE and press SET to see the current settings.

When a motion is detected, the area will blink.

- Press SET to return to the MODE1 menu.

7. As necessary, repeat to perform LEVEL adjustment and MASK setting by checking on the DISPLAY MODE screen.

**Notes:**

- In systems other than Panasonic, select OFF for MOTION DET to prevent system devices from confusing time-code signal with alarm signal.
- Set MASK SET over the areas where leaves or curtains etc. are swaying.
- Adjust the detection level to prevent detection from confusing motion with noise under low light conditions.
- It takes about 0.2 seconds for the alarm signal to reach the VCR's alarm terminal after detection.
- The motion/scene change detection is not specifically intended to prevent theft or fire.

**Motion Detector**

The motion detector divides the screen into 48 blocks and monitors changes in the luminance in each block. When it detects any change (movement) in the image, it outputs an alarm signal. When a change (movement) in the image is detected while in the auto mode, the alarm signal is output and the camera stops at the preset position for a specified amount of time.

**Demo Mode**

The demo mode divides the screen into 48 blocks and monitors changes in the luminance in each block. It also masks any part of the picture where there is a change in average luminance that exceeds the currently specified detection sensitivity level. The demo mode results can be used to determine the optimum detection sensitivity level (step 5) and the areas of the screen that need to be masked (step 1).

### About MODE2 of Motion Detection

- The camera will detect a scene change in the following cases.  
When the lens is fully sprayed or covered with a cloth, lid, or the like  
When the camera direction is suddenly changed
- The camera will not detect a scene change in the following cases.  
When a cloth with patterns covers the lens and it sways in the wind  
When some portions in the screen are not veiled  
When the screens are similar in scene patterns although the camera direction has changed
- The camera will faultily detect a scene change in the following cases.  
When an obvious brightness change arises (ex. On/Off of the lamps)  
When objects move continuously such as traffic in busy streets

## 9. Digital Noise Reduction Setting (DNR)

Select a DNR mode suitable to the camera site conditions. The default setting is HIGH.

**HIGH:** Greatly reduces noise, though it produces afterimages when objects move.

**LOW:** Slightly reduces noise, and produces less afterimages.

## 10. Resolution Setting (RESOLUTION)

Select a horizontal resolution mode. The default setting is HIGH.

**NORMAL:** Resolves more than 480 TV lines.

**HIGH:** Resolves typically 540 TV lines, though noise may increase when SENSE UP is activated in low lighting conditions.

## 11. Black and White Mode Setting (BW MODE)

1. Select BW MODE on the CAMERA SETUP menu and press SET.

→ The BW MODE menu opens.

2. Select a mode for BW. The default setting is OFF.

**AUTO1:** Sets the mode to black-and-white if the picture is dark or to color if the picture is bright enough.

**AUTO2:** Functions the same as AUTO1, except this is applied to the use near infrared light. (wavelength  $\geq$  800nm).

**ON:** Sets the mode to black-and-white.

**OFF:** Sets the mode to color.

### Notes:

- There may be cases where AUTO1 or AUTO2 does not function well if the camera is aimed at subjects continuously moving or a scene filled with a single color such as a blue sky.
- It is possible to set up the back-focus mode to compensate for defocus liable to happen when the camera automatically switches between the color and black-and-white modes. Refer to p. 41. Back-focus Setting for details.

→ When AUTO1 or AUTO2 is selected, LEVEL and DURATION TIME appear.

3. Select a threshold LEVEL to switch between the color and black-and-white mode. The default setting is HIGH.

**HIGH:** Switches the mode at around 5 lux illumination.

**LOW:** Switches the mode at around 1 lux illumination.

4. Select a duration time to determine whether to switch the mode. The default setting is 30 seconds.

**Available time:** (Short) 10 s ↔ 30 s ↔ E 60 s ↔ 300 s (Long)

5. Select a burst signal mode. The default setting is ON.

**ON:** Supplies the (color) burst signal with black-and-white composite video.

**OFF:** Supplies no burst signal.

**Note:** Using ON is usually recommended. Try both ON and OFF to match to connected devices (recorders, monitors, etc.) that have different characteristics.

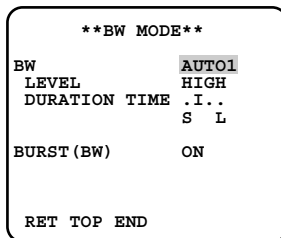

## 12. Privacy Zone Setting (PRIVACY ZONE)

Perform settings of up to eight privacy zones where you wish to veil the monitor screen.

1. Select ON(1), ON(2) or OFF for PRIVACY ZONE on page 2 of the CAMERA SETUP menu and press SET. The default setting is OFF.

**ON (1):** Veils the zone with gray.

**ON (2):** Veils the zone with mosaic.

**OFF:** Displays pictures normally.

→ The ZONE NUMBER selection menu opens.

2. Select a zone number on the top line using the [LEFT] and [RIGHT] buttons and press SET. The zone number followed by an asterisk \* indicates that it has been already registered.

→ POSITION, SCALE, and a frame appear on the menu.

3. Select →PUSH SW for POSITION and press SET.

→ Position selection becomes available.

4. Move the picture portion to be veiled to the center of the frame using the [LEFT], [RIGHT], [UP], or [DOWN] button.

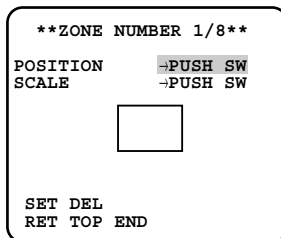
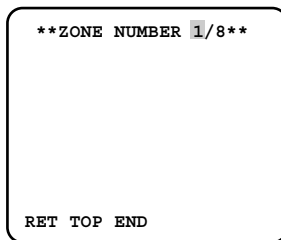

5. Select →PUSH SW for SCALE and press SET.  
→ Zone scale adjustment becomes available.
6. Adjust the zone scale using the [LEFT], [RIGHT], [UP], or [DOWN] button.
7. To apply the settings, move the cursor to SET and press SET.  
→ The screen returns to the ZONE NUMBER selection menu.  
To delete the settings, select DEL and press SET.

### 13. Electronic Zoom (EL-ZOOM)

1. Move the cursor to EL-ZOOM.
2. Select ON or OFF by pressing L or R.  
The factory default setting is OFF.  
**ON:** x2 electronic zoom is available with the ZOOM switch on the controller.  
**OFF:** The electronic zoom function is disabled.
3. While the cursor is on EL-ZOOM, press S.  
The EL-ZOOM setting menu appears.
4. Move the cursor to PUSH SET for ZOOM and press S to display the ZOOM setting menu.
5. Press U or D to zoom in or out the image.
6. Move the cursor to PUSH SET for PAN/TILT and press the [SET] button. The PAN/TILT setting menu appears.
7. Press [LEFT], [RIGHT], [UP], or [DOWN] button to change the angular field of view.
8. To return to the EL-ZOOM setting menu, press the [SET] button.

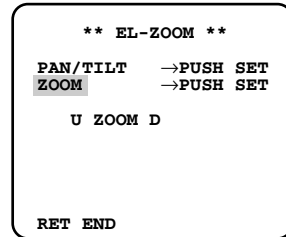
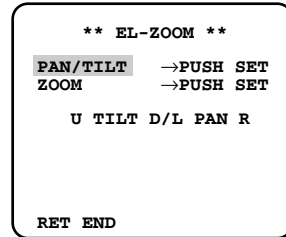

### 14. Camera Picture Upside Down Positioning (UPSIDE-DOWN)

1. Move the cursor to UPSIDE-DOWN.
2. Select ON when you want to turn the picture upside down.

### 15. Auto Image Stabilizer (STABILIZER)

This function electronically compensates for an unstable camera image due to movement of a mounting pole or bracket. The default setting is OFF.

**ON:** Automatically compensates for an unstable image.

**OFF:** Image stabilizer will not operate.

**Notes:**

- When set to ON, some effective pixels on the edge of the CCD are used by the stabilization function. This may result in a small reduction in resolution and a narrower angle of view. After activating the image stabilizer function, check that the field of view is correct.



- Image stabilization may not function where there is excessive camera movement or when the scene is low light or low contrast objects.

## 16. LENS

- When using WV-CW484F or WV-CW484S (with a Panasonic x2 varifocal lens), select PANASONIC.
- When using WV-CW484FK or WV-CW484SK (with a lens other than Panasonic), select OTHER.

## 17. Back-focus Setting (BACK-FOCUS SETUP)

If applicable, perform adjustment of the lens focus as described in p. 26 "Before Back-focus Adjustment" on the INSTALLATION page. Perform adjustment of the back focus (flange-back: the gap between the lens and focal plane) remotely on this menu using a system controller. After installation, you can perform this adjustment when defocus arises that may be caused by long-term use, environmental changes, etc.

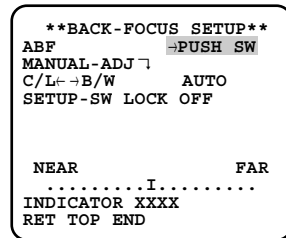

**Important:** Do not use the ABF function for continuous or repetitive purposes (ex. autofocus etc.). This function is to be used to correct defocus caused by switching between color and black - and - white when/after installing the camera.

1. Select BACK-FOCUS on the WV-CW484 TOP menu and press SET.  
→ The BACK-FOCUS SETUP menu opens.
2. Select ABF and press SET.  
→ Adjustment is automatically performed.

### Notes:

- Performing ABF will function to obtain the best focus around the center areas in a scene.
  - Performing ABF is available only when OFF, X2 AUTO, or X2 FIX is selected for SENS UP.
3. Select MANUAL-ADJ and press SET if manual adjustment is required.  
The manual back-focus adjustment screen will open.
    - Use the [LEFT] and [RIGHT] buttons for 2 seconds or more to move the "I" cursor and obtain a proper focus.  
→ Refer to the 4-digit number on the second bottom line. The larger the number is, the better the focus will be.
    - Select RET and press SET to go back to the menu setup.

4. Select a mode for C/L ↔ B/W. The default setting is AUTO.
  - AUTO:** Adjusts the back-focus automatically every time the camera switches the mode between color and black-and-white. AUTO is usable only when OFF, X2 AUTO, or X2 FIX is selected for SENS UP.
  - PRESET:** Adjusts the back-focus to the positions for color mode and black-and-white mode that are preset by performing step 2 (automatic) or step 3 (manual) under the respective light conditions.
  - FIX:** Fixes the back-focus after adjustment.
  
5. Select ON or OFF for SETUP-SW LOCK. The default setting is OFF.
  - OFF:** Enables the SET button to open the back-focus adjustment screen while the camera picture is displayed.
  - ON:** Disables the SET button from opening the back-focus adjustment screen.
  
6. To reset the back focus to the default setting, press the [LEFT] and [RIGHT] buttons simultaneously.

**Notes:**

- Select FIX or PRESET and adjust manually the back-focus when automatic adjustment is hindered by the following conditions.
  1. Dirt or a water drip attached to window glass  
This causes defocus on the object beyond the glass.
  2. Objects in low lighting conditions
  3. Objects extremely bright
  4. Flat contrast objects such as white wall or fine felt
  5. Objects placed on the outskirts of the scene
  6. More than one object placed with a certain depth
  7. An object having a certain depth
  8. Objects continuously moving such as busy streets
  9. Objects extremely flickering
  10. Objects consisting of parallel horizontal lines such as a window shade
- Matsushita Electric Industrial Co., Ltd shall not be responsible for any inconvenience, damage or loss caused by or attribute to inappropriate settings for the ABF function.

## 18. Special Menu (SPECIAL SETUP)

Select SPECIAL on the WV-CW484 TOP menu and press SET.

→ The SPECIAL SETUP menu opens.

### 18-1. Chroma Level Setting (CHROMA GAIN)

Move the "I" cursor to adjust the chroma level.

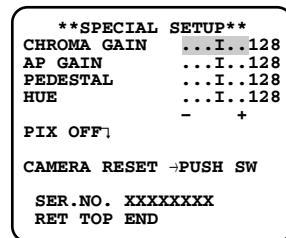

## 18-2. Aperture Gain Setting (AP GAIN)

Move the "I" cursor to adjust the aperture gain level.

Lower the level when moire (a kind of noise, optical interference) appears on the screen as part of minute crosshatch pattern, etc.

## 18-3. Pedestal Level Setting (PEDESTAL)

Move the "I" cursor to adjust the pedestal level (black level).

## 18-4. Chroma Phase (Hue) Setting (HUE)

1. Move the cursor to HUE.
2. Move the "I" cursor to adjust the hue (chroma phase) level.

## 18-5. Pixel Compensation Setting (PIX OFF)

Perform settings to compensate a maximum of 16 blemish pixels on the pickup device.

1. Select PIX OFF and press SET.  
→ The PIX OFF menu opens with numbers from 1 to 16.
2. Select a number and press SET.  
→ The PIX OFF assignment screen opens with a + cursor.
3. Move the cursor to the center of a blemish position until its appearance becomes less obvious. Finally, press SET.  
→ The horizontal and vertical positions (coordinate) of the blemish will be displayed with a 6-digit number on the second bottom line.  
→ The blemish position is registered to be compensated.  
→ The screen returns to the PIX OFF menu that displays the number followed by an asterisk if it has been registered.

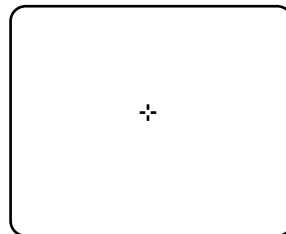
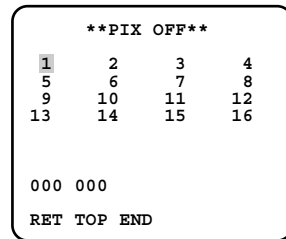

4. Repeat above steps as necessary.
5. To cancel a registration, select an asterisked number in the PIX OFF menu and press SET.  
→ The PIX OFF assignment screen opens.  
Hold down the the [LEFT] and [RIGHT] buttons simultaneously for 2 seconds or more.  
→ The PIX OFF menu appears displaying the number without an asterisk if its registration has been cancelled.

## **18-6. To reset to the default settings (CAMERA RESET)**

1. Select CAMERA RESET.  
→ The PUSH SW is highlighted.
2. While holding down the [LEFT] and [RIGHT] buttons, press SET for 2 seconds or more.  
→ The camera will return to the default settings.

**Note:** PIX OFF setting cannot be initialized.

## **18-7. The serial number of the camera will be displayed.**

# Troubleshooting

Before asking for repairs, check the symptoms with the following table.  
Contact your dealer if a problem cannot be solved even after checking and trying the solution or if the problem is not described below.

Symptom	Cause/solution	Reference pages
<p>No image is displayed.</p>	<ul style="list-style-type: none"> <li>• Is AC 24 V or DC 12 V power supply connect to the power supply terminal? Is the video output cable connected to the video connector of the monitor? → Confirm the cables are firmly connected.</li> </ul>	23
	<ul style="list-style-type: none"> <li>• Are the brightness and contrast of monitor properly adjusted? → Confirm the monitor.</li> </ul>	-
<p>Images are displayed blurry.</p>	<ul style="list-style-type: none"> <li>• Aren't there dusts or dirt on the lens? → Check if there are dust or dirt on the lens.</li> </ul>	-
	<ul style="list-style-type: none"> <li>• Is the focus adjusted correctly? → Check if the focus is adjusted correctly.</li> </ul>	21

Symptom	Cause/solution	Reference pages
<p>The power cord insulation is damaged.</p>	<ul style="list-style-type: none"> <li>The power cable is worn out. This may result in electric shock or a fire. Unplug the power plug from the AC outlet immediately, and refer to qualified service personnel.</li> </ul>	<p>-</p>
<p>The power cord gets hot during use.</p>		
<p>The power cord gets hot when bent or stretched.</p>		

# Specifications

## General specifications

Power source and power consumption:	24 V AC 60 Hz, 11 W (With heater), 12 V DC 470 mA
Ambient temperature:	-10 °C - +50 °C {14 °F to 122 °F} -30 °C - +50 °C {-22 °F to 122 °F}*
Ambient humidity:	90 % or less
Water resistance:	IEC60529 (IP66, Against ingress of water with harmful effects powerful jetting)** (Camera unit)
Dimensions:	ø154 mm (W) x 141.2 mm (H) {ø6.06" (W) x 5.55" (H)} (excluding connectors/terminals)
Weight:	Camera: Approx. 1.3 kg {2.87 lbs.} Camera attachment: Approx. 100 g {0.22 lbs.}

\* With Heater Unit WV-CW4H (option)

\*\* Applicable only when the installation and waterproof process are done properly

## Camera

Image sensor:	1/3" interline transfer CCD
Effective pixels:	768 (H) x 494 (V)
Scanning area:	4.8 mm (H) x 3.6 mm (V)
Scanning method:	2:1 interlace scan
Scanning frequency:	Horizontal: 15.734 kHz Vertical: 59.94 Hz
Resolution:	Horizontal 480 TV lines (C/L Normal), 540 TV lines typ., 520 TV lines min. (C/L High), 570 TV lines (B/W)
Signal-to-noise ratio:	50 dB (Equivalent to AGC Off, weight On)
Dynamic range:	52 dB typ
Minimum illumination:	1.5 lx { x.xx footcandle} at F1.4 (C/L), 0.16 lx {x.xx footcandle} at F1.4 (B/W),
Video output:	VBS 1.0 V [P-P] NTSC composite 75 Ω/BNC connector
Lens mount:	CS-mount

## Major items on menu setup (Factory default settings are underlined.)

Language:	English, French, German, Spanish, Italian, Russian, Japanese, or Chinese
Camera ID:	Up to 16 characters
Light control:	ALC
Super Dynamic 3:	<u>ON</u> or OFF
Electronic shutter speed:	<u>OFF (1/60)</u> , 1/100, 1/250, 1/500, 1/1 000, 1/2 000, 1/4 000, 1/10 000 s
AGC:	ON ( <u>HIGH</u> /MID/LOW), or OFF
Sensitivity enhancement:	<u>OFF</u> , x2 AUTO, x4 AUTO, x6 AUTO, x10 AUTO, x2 FIX, x4 FIX, x6 FIX, x10 FIX, x16 FIX, x32 FIX
Synchronization:	Multiplexed vertical drive (VD2), Line-locked, or <u>Internal</u>
White balance:	<u>ATW1</u> , ATW2, or AWC
Motion detection:	MODE1, MODE2, or <u>OFF</u>

Digital noise reduction:	<u>High</u> or Low
Resolution:	Normal or <u>High</u>
Black-and-white mode:	AUTO1, AUTO2, ON, or <u>OFF</u>
Privacy zone:	ON (1/2), or <u>OFF</u>
Auto image stabilizer:	ON or <u>OFF</u>
Back focus adjustment:	ABF, MANUAL, AUTO/PRESET/FIX
Special:	Chroma, Aperture, Pedestal, HUE adjustable

**Lens (WV-CW484S, WV-CW484F)**

Type:	x2 varifocal
Focal length:	3.8 mm – 8.0 mm
Maximum aperture ratio:	1:1.4 (Wide), 1:1.8 (Tele)
Focusing range:	1.2 m - ∞ (3.9 ft. - ∞)
Angular field of view:	Horizontal: 35.6° (Tele) - 73.6° (Wide) Vertical: 26.6° (Tele) - 53.4° (Wide)
Ambient operating temperature:	-10°C - +50°C {14°F - 122°F} -30°C - +50°C {-22°F - 122°F}*

\* With Heater Unit WV-CW4H (option)

## Standard Accessories

- Operating Instructions (This document) ..... 1 pc.
- Warranty ..... 1 pc.

The following parts are used during installation procedures.

- Camera attachment ..... 1 pc.
- Bit for tamperproof screw ..... 1 pc.
- Butyl tape ..... 1 pc.

## Optional Accessories

- Clear dome cover WV-CW4C
- Weight: Approx. 110 g {0.24 lbs.}
- Heater Unit WV-CW4H
- Weight: Approx. 40 g {0.08 lbs.}
- Mounting Bracket WV-Q114
- Weight: Approx. 470 g {1.04 lbs.}
- Ceiling Mount Bracket WV-Q166
- Weight: Approx. 660 g {1.45 lbs.}





**Panasonic System Solutions Company,**  
Unit Company of Panasonic Corporation of North America

**Security Systems**

[www.panasonic.com/security](http://www.panasonic.com/security)

For customer support, call 1.877.733.3689

**Executive Office:** Three Panasonic Way 2H-2, Secaucus, New Jersey 07094

**Zone Office**

**Eastern:** Three Panasonic Way, Secaucus, New Jersey 07094

**Central:** 1707 N. Randal Road, Elgin, IL 60123

**Southern:** 1225 Northbrook Parkway, Suwanee, GA 30024

**Western:** 6550 Katella Ave., Cypress, CA 90630

**Panasonic Canada Inc.**

5770 Ambler Drive, Mississauga,  
Ontario, L4W 2T3 Canada (905)624-5010  
<http://www.panasonic.ca>

**Panasonic Sales Company**

Division of Panasonic Puerto Rico Inc.  
San Gabriel Industrial Park 65th Infantry Ave. KM. 9.5 Carolina  
P.R. 00985(809)750-4300